

# Termocoppia "J" ( Fe - Co ) per stampo pressa

"J" ( Fe - Co ) thermocouple for mould press

RoHS

Compliant

Tolleranza termoelemento secondo la norma CEI EN 60584-1 Classe 1  
Tolerances thermoelement according to CEI EN 60584-1 Class 1  
Tolleranze dimensionali +/- 3% - Dimensional tolerances +/- 3%

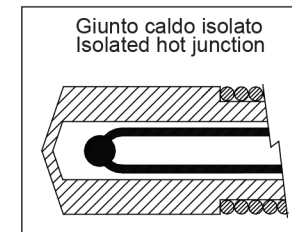
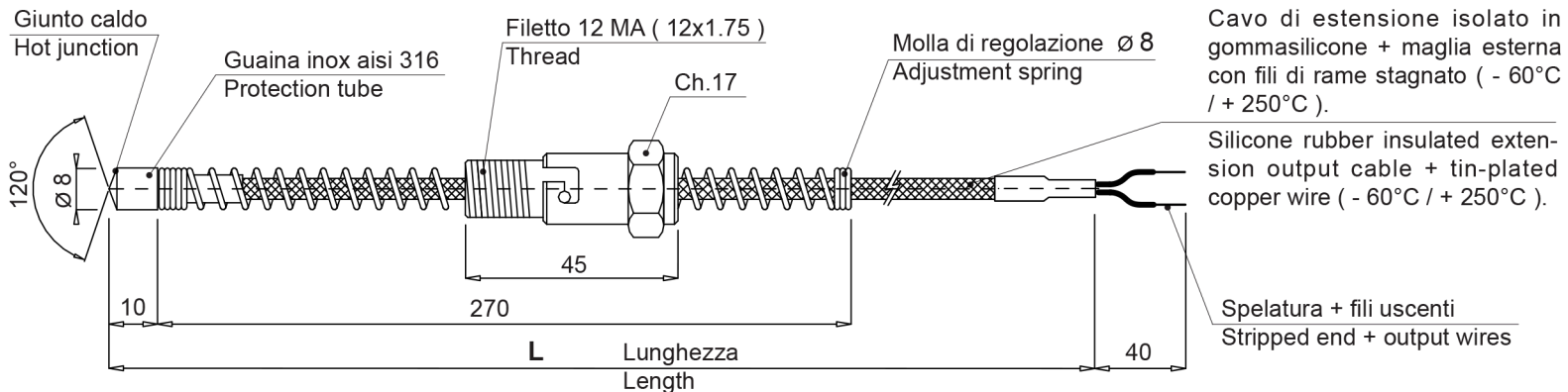

Tutte le quote sono espresse in mm  
All dimensions are in millimeters

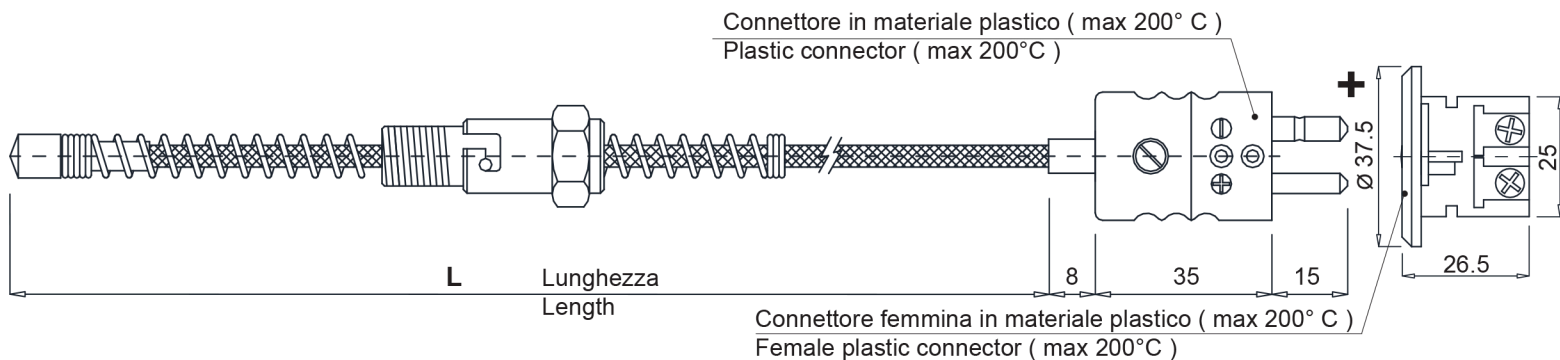
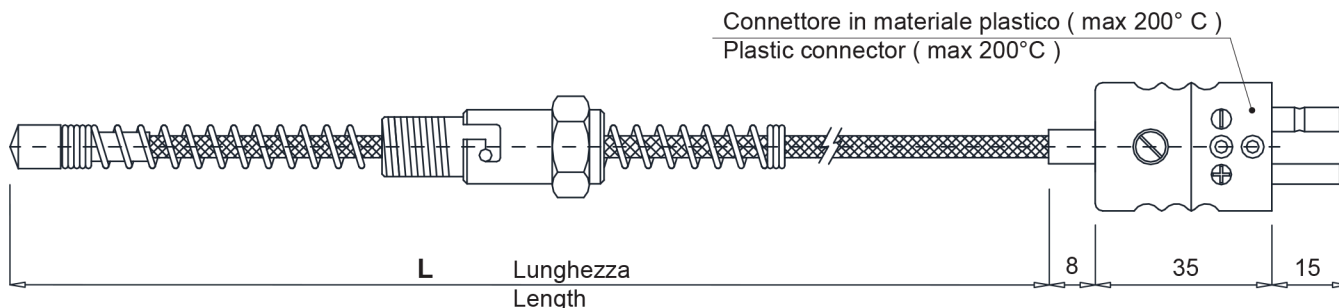

0

1

2

Lunghezza L  
Length

01	1 mt
02	2 mt
03	3 mt
04	4 mt
05	5 mt
06	6 mt
07	7 mt
08	8 mt
09	9 mt
10	10 mt
15	15 mt
20	20 mt
25	25 mt

La temperatura di lavoro della termocoppia è subordinata alla temperatura di lavoro del cavo utilizzato  
The operating temperature of the thermocouple is subject to the working temperature of the cable adopted



VEGA srl  
Via Industria, 14 - Z.I. Scovizze  
36033 Isola Vicentina (VI) - ITALY

mail@vegacer.com  
Ph. +39 0444976414  
Fax +39 0444809124