

Termoresistenza PT100 per stampo pressa (max 200°C)

PT100 resistance thermometer for mould press (max 200°C)

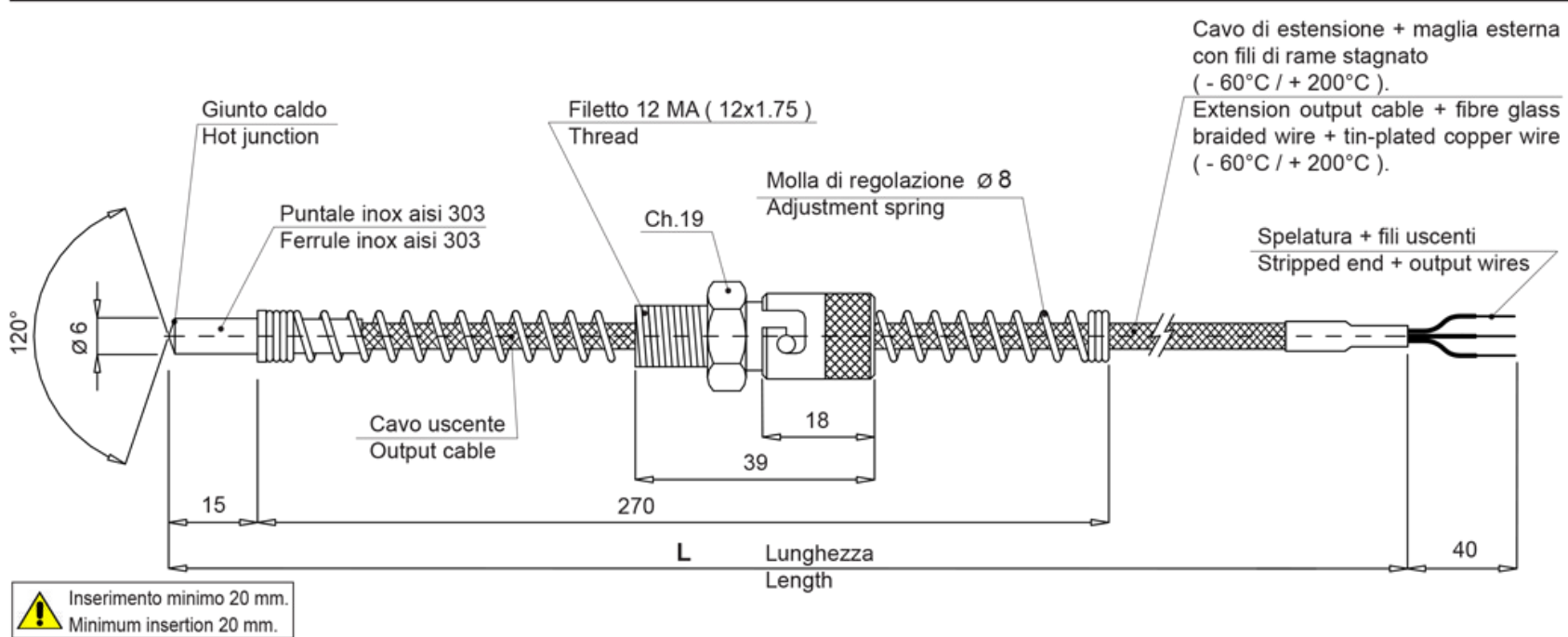

Tolleranze dimensionali +/- 3% - Dimensional tolerances +/- 3%



Lunghezza L
Length

01	1 mt
02	2 mt
03	3 mt
04	4 mt
05	5 mt
06	6 mt
07	7 mt
08	8 mt
09	9 mt
10	10 mt
15	15 mt
20	20 mt
25	25 mt
30	30 mt
35	35 mt
40	40 mt
45	45 mt
50	50 mt



Tutte le quote sono espresse in mm
All dimensions are in millimeters

Tolleranza elemento sensibile (IEC751)
Tolerance of sensitive element

Classe **B** (+/- 0,30°C a 0°C)
Class **B**

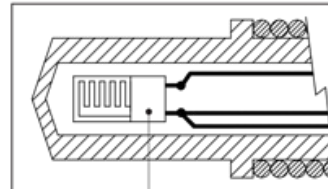

Elemento sensibile (RTD)
Sensible element (RTD)

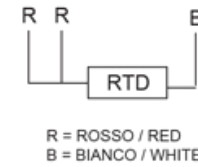

Schema di collegamento
Connection diagram



VEGA srl
Via Industria, 14 - Z.I. Scovizze
36033 Isola Vicentina (VI) - ITALY

mail@vegacer.com
Ph. +39 0444976414
Fax +39 0444809124